

Side View

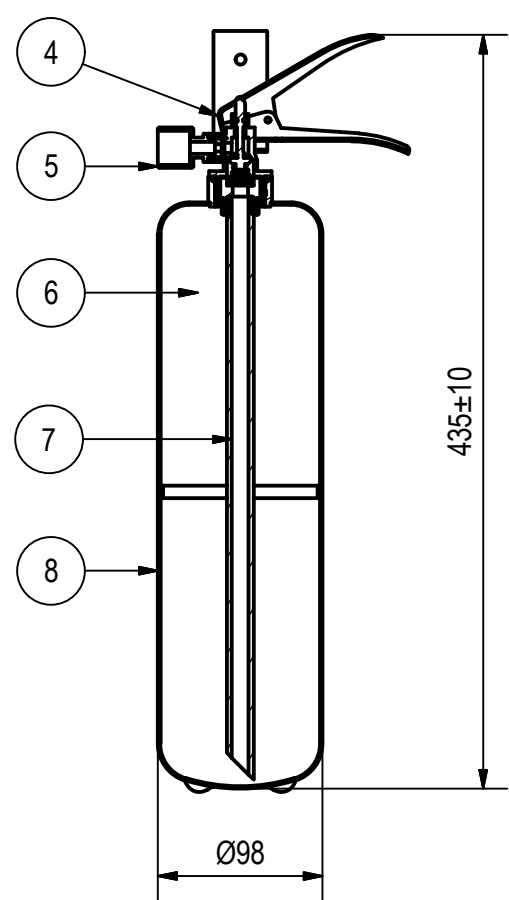

Internal View

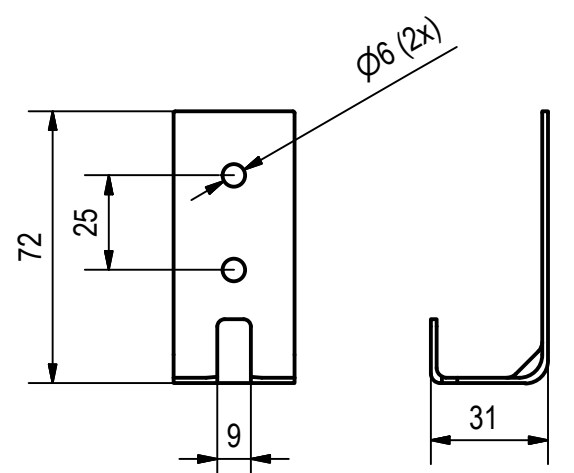

Bracket Detail

Parts List				
Item	Description	Specification	Com No.	Qty.
1	Pressure Gauge	Working Temperature Range : -20 deg C To 60 deg C	03000200	1
2	Hook Bracket	Materials : 1.5mm Mild Steel Finishing : Chrome Plated	03021500	1
3	Artwork	Silkscreen	NA	1
4	Valve Assembly	Model 06E20	03129600 / 03013103	1
5	Discharge nozzle	Material : UPVC Plastic	03003900	1
6	Medium	40% ABC Dry Chemical Powder	03024700	2Kg
7	Syphon Tube	Material : UPVC Plastic	03036800	1
8	Empty Cylinder	Material : JISG3141 1.5mm Cold Roll Sheet Finishing : Red Epoxy Powder Coated	03066300	1

Technical Specification	
Description	Specification
Working Temperature	-20 deg C To 60 deg C
Working Pressure	14 Bar
Test Pressure, PT	27 Bar @ 30 Sec
Maximum Allowable Pressure, PS	18 Bar
Fire Rating	13A/55B
Gross Weight	3.65 Kg

Ordering Matrix				
Com No.	Brand	Approval	Remarks	
20801018 00000	COMBAT	LPCB	BS EN3	
20801000 00000	COMBAT	SETSCO	SS EN3	

LINGJACK ENGINEERING WORKS PTE LTD
 NO.1 WOODLANDS TERRACE #03-01
 LINGJACK INDUSTRIAL BUILDING
 SINGAPORE 738471
 TEL:(65)6759 4163 FAX:(65)6758 7513
 E-MAIL:COMBAT@LINGJACK.COM
 WEBSITE:WWW.COMBAT.COM.SG

Customer : _____ Project : _____
 Title : DCP ABC Portable Fire Ext, Stored Pressure 2KG (C-2ASE)
 Drawing No. : 20801018 Com. No. : _____
 This drawing contains proprietary information and should not be reproduced or use in any way without written permission from Lingjack Engineering Works Pte Ltd.

Scale : NTS Sheet : 1/1
 3rd Angle Projection :

10.02.09	Approval Drawing.	Tan CP	Lucas	00	A
Date	Description	Drawn	Approved	GA Rev	Pro Rev