

Side View

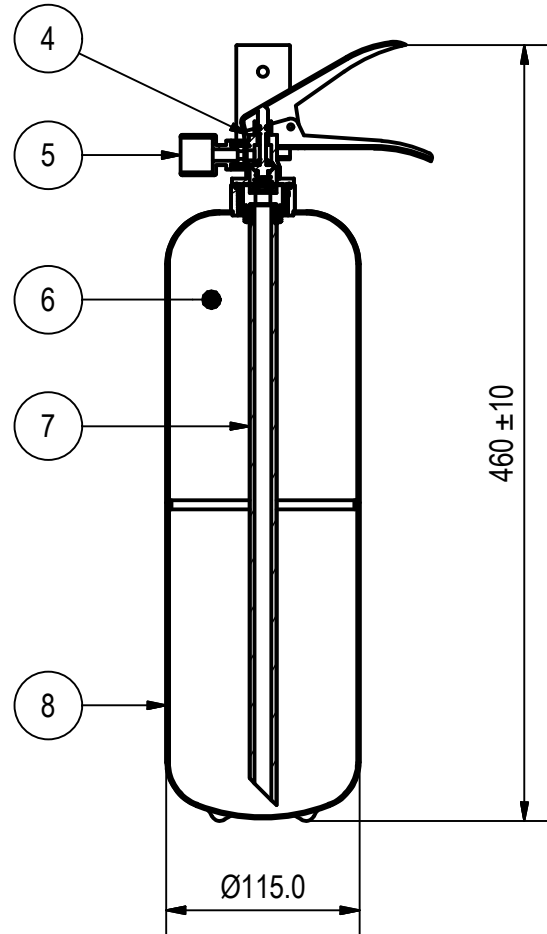

Internal View

460 ±10

Ø115.0

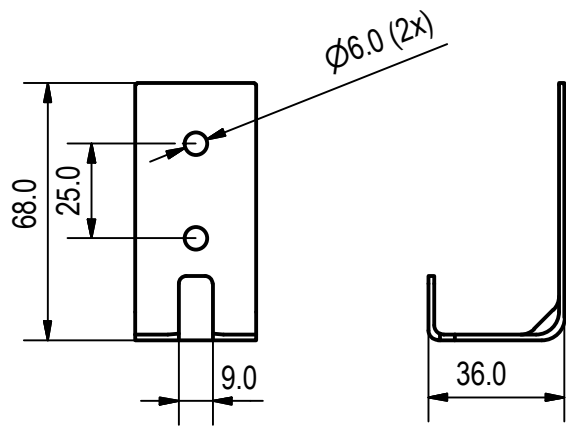

Bracket Detail

Parts List				
Item	Description	Specification	Com No.	Qty.
1	Pressure Gauge	Working Temperature Range : -20 deg C To 60 deg C	03000200	1
2	Hook Bracket	Materials : Min 1.5mm Thick Mild Steel Finishing : Chrome Plated	03010300	1
3	Artwork	Silkscreen	NA	1
4	Valve Assembly	Refer To Technical Drawing 06E20	03013103	1
5	Discharge nozzle	Material : UPVC Plastic	03003900	1
6	Medium	40% ABC Dry Chemical Powder	03024700	3Kg
7	Syphon Tube	Material : UPVC Plastic	03036700	1
8	Empty Cylinder	Material : JISG3141 Cold Roll Sheet, 1.5mm Thick Finishing : Red Epoxy Powder Coated	03066500	1

Technical Specification	
Description	Specification
Working Temperature	-20 deg C To 60 deg C
Working Pressure	14 Bar
Test Pressure, PT	27 Bar @ 30 Sec
Maximum Allowable Pressure, PS	18 Bar
Fire Rating	13A/55B
Gross Weight (Approx.)	5.0 KG

Ordering Matrix			
Com No.	Brand	Approval	Remarks
20801220 00000	COMBAT	LPCB	BS EN3
20801200 00000	COMBAT	TUV	SS EN3

**LINGJACK ENGINEERING WORKS PTE LTD**  
 NO.1 WOODLANDS TERRACE #03-01  
 LINGJACK INDUSTRIAL BUILDING  
 SINGAPORE 738471  
 TEL:(65)6759 4163 FAX:(65)6758 7513  
 E-MAIL:COMBAT@LINGJACK.COM  
 WEBSITE:WWW.COMBAT.COM.SG

Customer : \_\_\_\_\_ Project : \_\_\_\_\_  
 Title : DCP ABC Portable Fire Ext, Stored Pressure 3KG (C-3ASE)  
 Drawing No. : 20801200 Com. No. : \_\_\_\_\_  
 This drawing contains proprietary information and should not be reproduced or use in any way without written permission from Lingjack Engineering Works Pte Ltd.

Scale : NTS Sheet : 1/1  
 3rd Angle Projection :

10.02.09	Approved Drawing	TanCP	Lucas	00	A
Date	Description	Drawn	Approved	GA Rev	Pro Rev